

# Parts List For TBS4500PRC & TBS4500PRCGY Spreaders

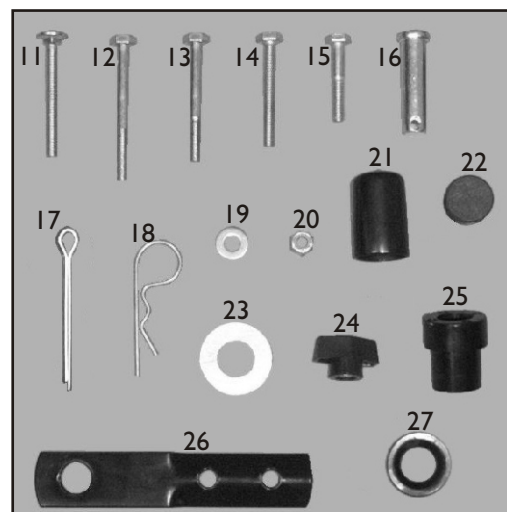

# TBS4500PRC & TBS4500PRCGY Trail Behind Broadcast Spreader

## Assembly Instructions & Parts List

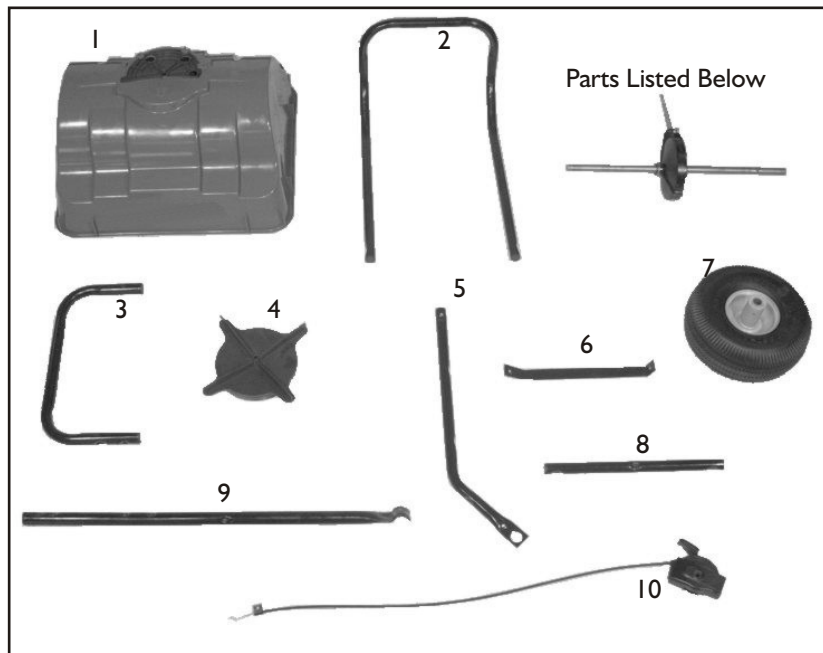

Parts referenced with \*\* have two color options.

Gear Case Components

Ref No	Part No	Description	Qty	Ref No	Part No	Description	Qty
1	2877	Hopper	1	21	2582	Tube Cap	4
2	2908B	Wrap-Around Support (Black)	1	22	1053	7/8 Tube Plug	2
**	2908GY	Wrap-Around Support (Gray)	1	23	1646	5/8 Flat Washer	3
3	2282B	Control Cable Holder (Black)	1	24	2828	1/4 Wing Nut	1
**	7182G	Control Cable Holder (Gray)	1	25	6214	5/8 Wheel Bushing	2
4	2614	Spinner Disc	1	26	1062B	Clevis Plate (Black)	2
5	2900B	Hopper Support (Black)	2	**	1062GY	Clevis Plate (Gray)	2
**	2900GY	Hopper Support (Gray)	2	27	3333	5/8 Retaining Ring	1
6	2284B	Support Bracket (Black)	2	28	2174	3/8 Retaining Ring	1
**	2284GY	Support Bracket (Gray)	2	29	2879A	Spinner Shaft Assembly	1
7	3467	Wheel	2	30	2973	3/8 Nylon Bushing	3
8	2280B	Cross Brace (Black)	1	31	2978	7/8 Spring Clamp	1
**	2280GY	Cross Brace (Gray)	1	32	2983	1/4 Grease Zerk	1
9	2285B	Tow Bar (Black)	1	33	2976	Rear Gear Case Housing	1
**	7185G	Tow Bar (Gray)	1	34	2984	1/4-28 x 1/2 Long Hex Bolt	1
10	2438	Control Cable	1	35	1807	1/4 Lock Washer	1
11	1868	1/4 x 2-1/4 Carriage Bolt	1	36	2977	15/16 Spring Clamp	2
12	2385	1/4 x 2-1/2 Hex Head Bolt	4	37	2970	5/8 Nylon Bushing	2
13	2101	1/4 x 2-1/4 Hex Head Bolt	2	38	2971	Drive Gear	1
14	1086	1/4 x 2 Hex Head Bolt	2	39	2571	Axle	1
15	6129	1/4 x 1-1/2 Hex Head Bolt	4	40	2975	Front Gear Case Housing	1
16	1840	Clevis Pin	1	41	2979	3/16 x 1-1/4 Split Pin	1
17	2576	3/16 x 2 Cotter Pin	1	**	2906	Rain Cover (Not Shown)	1
18	1042	Hitch Pin Clip	2				
19	1817	1/4 Flat Washer	4				
20	1558	1/4 Lock Nut	12				

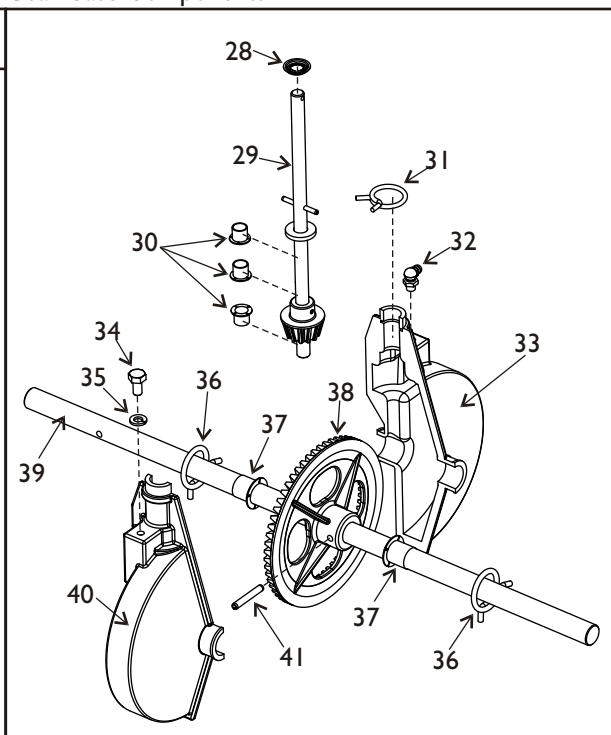

**TIP:** Many of these hardware parts can be purchased at your local hardware store.

**CUSTOMER SUPPORT**

At Precision Products, Inc. delivering quality, value and outstanding service is our goal. However, sometimes parts do become damaged or lost during transport from our facilities to the store. **If you have any problems, please do not return this merchandise to the store. Call us and we will take care of any problem you may have with this unit. Phone (800) 225-5891 Ext. 204**

<p><b>HOW TO ORDER</b></p> <p><b>REPLACEMENT PARTS:</b></p> <p>When ordering parts always give model number, part number and part description.</p>	<p><b>Send To:</b> Parts Division 316 Limit Street Lincoln, IL 62656</p> <p><b>Phone (800) 225-5891</b> (217) 735-1590 Ext. 204</p> <p><b>FAX (217) 735-2435</b> www.precisionprodinc.com</p>
--	---



# ASSEMBLY INSTRUCTIONS FOR THE TBS4500PRC & TBS4500PRCGY

**ASSEMBLY TIP:** Loosely tighten nuts and bolts at first. Fully tighten when the spreader is completely assembled.

## Step 1

Attach the Tow Bar (9) to the center hole on the Cross Brace (8) using a 1/4 x 1-1/2 Hex Head Bolt (15) and a 1/4 Lock Nut (20).

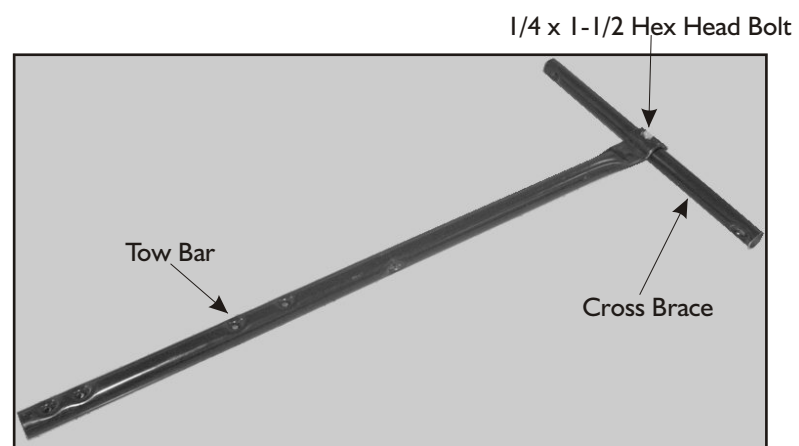

## Step 2

Attach Tow Bar / Cross Brace assembly to the two Hopper Supports (5) using two 1/4 x 2 Hex Head Bolts (14) and two 1/4 Lock Nuts (20).

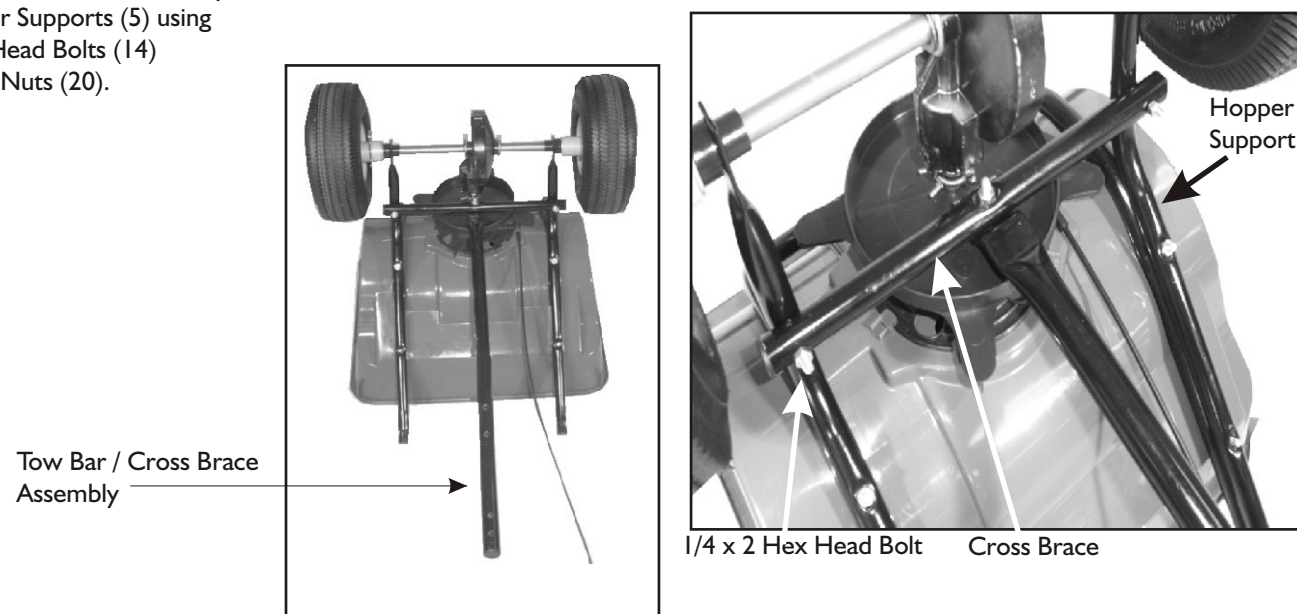

## Step 3

Attach both Support Brackets (6) to the Hopper Supports where the two bolts are exposed towards the top of the hopper. Secure with two 1/4 Lock Nuts (20).

Next, connect the two Support Brackets (6) to the Tow Bar (9) using a 1/4 x 1-1/2 Hex Head Bolt (15) and secure with a 1/4 Lock Nut (20).

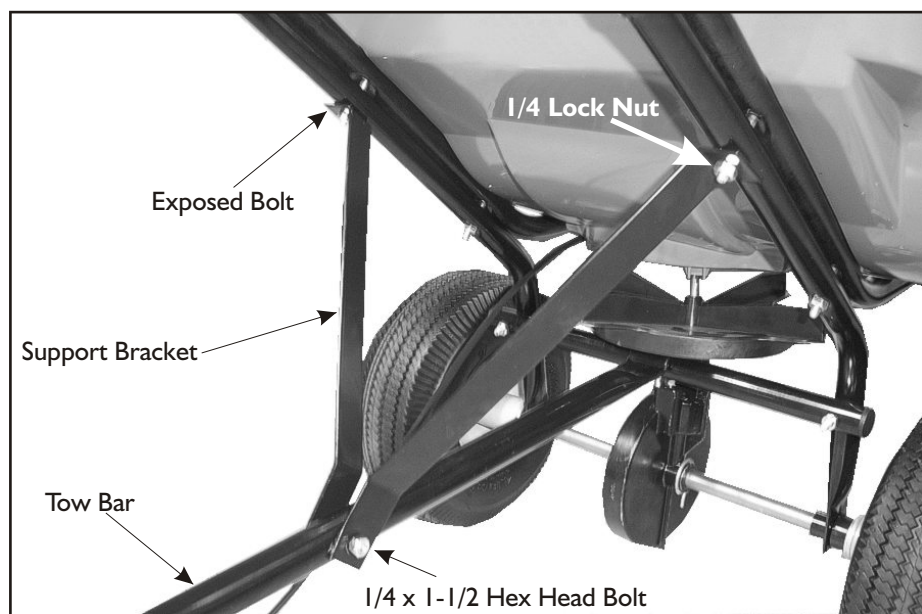

## Step 4

Fasten the Control Cable Holder (3) to the top of the Tow Bar (9) using two 1/4 x 2-1/4 Hex Head Bolts (13) and two 1/4 Lock Nuts (20). Attach the Control Cable (10) to the top of the Control Cable Holder using a 1/4 x 2-1/4 Carriage Bolt (11) and secure with a 1/4 Wing Nut (22),

Using a hammer, gently tap in the two 7/8 Tube Plugs (22) into the open ends of the Control Cable Holder (3) tube.

Attach Clevis Plates (26) to the end of the Tow Bar (9) using two 1/4 x 1-1/2 Hex Head Bolts (15) and securing with two 1/4 Lock Nuts (20). Insert the Clevis Pin (16) through the large hole on the Clevis Plates (26) and secure it with a Hitch Pin Clip (18).

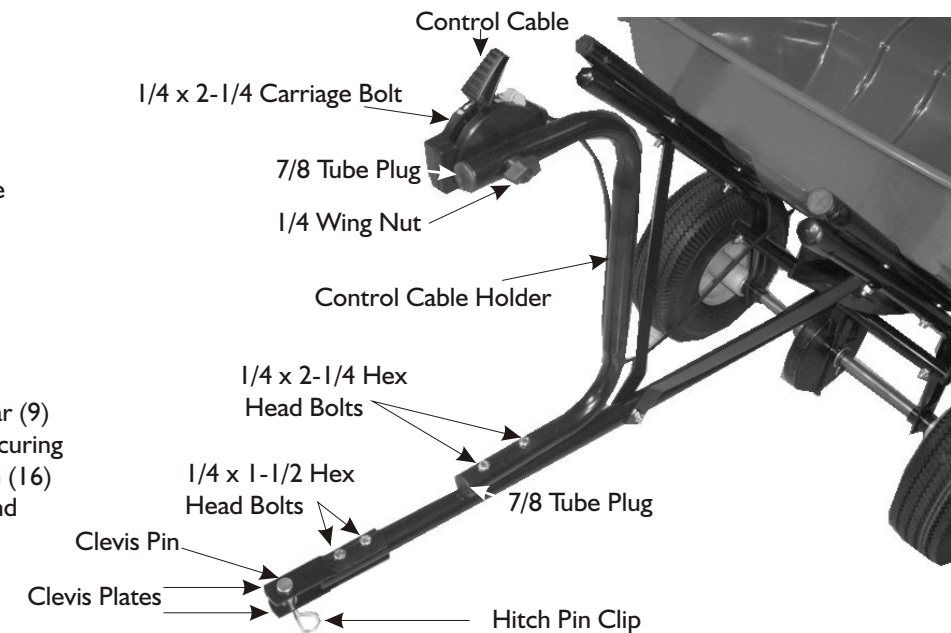

## USING YOUR SPREADERS CONTROLLER

Settings are made by pushing down on the Calibration Indicator button and setting to the desired number on the Control Cable assembly.

## SEE APPLICATION CHART FOR SETTING INFORMATION.

**ON -- Push the Control Lever forward until it stops against Calibration Button.**

**OFF -- Pull Control Lever back until it stops.**

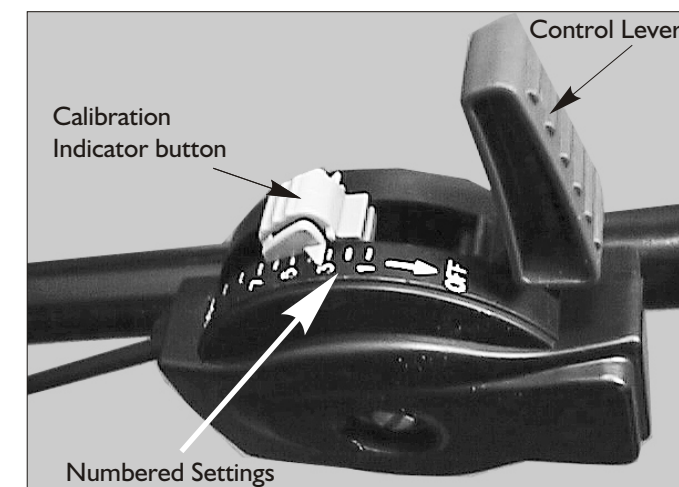

## BROADCAST SPREADER OPERATION

1. Always have the control lever in OFF position before filling the hopper.
2. Always pull the spreader forward to operate; do not operate in reverse.
3. Start moving forward before pushing the control lever to the ON position. Pull the control lever to OFF position before stopping or turning.

**DO NOT** allow spreader to sit stationary with material in the hopper and control lever in the ON position.

4. Pull the spreader at a steady speed (approximately 3 - 4 mph is recommended).
5. To avoid misses or striping, space each pass across the lawn so approximately 20% of the spread width overlaps onto the previous pass. This provides a "feathered" overlap to even out distribution over the width of the spread.

**CAUTION:** care must be taken with any weed killer, pesticide, or combination product. They can be harmful to other plant life in the yard.

**Recommended operating weight – 90 lbs.**

## MAINTENANCE INSTRUCTIONS

1. Empty hopper after each use. Do not store spreader with material left in hopper.
2. Wash spreader thoroughly and wipe dry.
3. Lubricate all moving parts. Use a grease gun to apply grease to the gearbox assembly. **CAUTION: Use a reasonable amount of grease. DO NOT pack gearbox full of grease.** Apply oil to spinner shaft (including area shaft extends through hopper), slide plate and where the spinner shaft and axle extend through the gearbox.

## LIMITED WARRANTY

This unit is warranted against defects in materials and workmanship to the original purchaser, under normal use and service, for a period of ninety (90) days from date of sale. During the Warranty Period, we will repair or replace at our option free of charge to the original purchaser, any part of the Unit that our examination shows to be defective in workmanship or materials. This Warranty **Does Not** apply to damage caused by transit, misuse, abuse, neglect, accident, normal wear, or alterations by unauthorized persons.